

RS5100

Ring Scanner

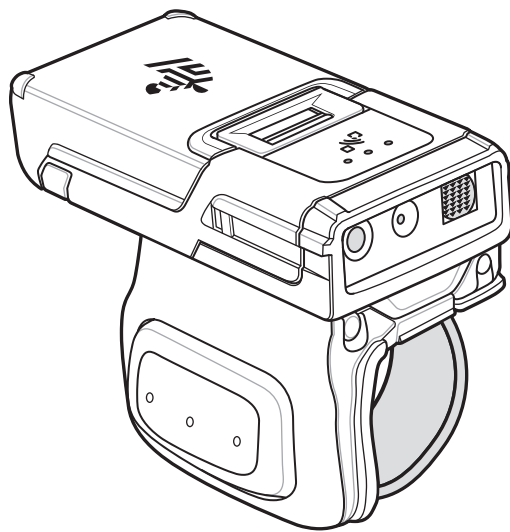

Quick Start Guide



ZEBRA

Copyright

ZEBRA and the stylized Zebra head are trademarks of Zebra Technologies Corporation, registered in many jurisdictions worldwide. All other trademarks are the property of their respective owners. ©2019 Zebra Technologies Corporation and/or its affiliates. All rights reserved.

COPYRIGHTS & TRADEMARKS: For complete copyright and trademark information, go to www.zebra.com/copyright.

WARRANTY: For complete warranty information, go to www.zebra.com/warranty.

END USER LICENSE AGREEMENT: For complete EULA information, go to www.zebra.com/eula.

Terms of Use

- Proprietary Statement

This manual contains proprietary information of Zebra Technologies Corporation and its subsidiaries (“Zebra Technologies”). It is intended solely for the information and use of parties operating and maintaining the equipment described herein. Such proprietary information may not be used, reproduced, or disclosed to any other parties for any other purpose without the express, written permission of Zebra Technologies.

- Product Improvements

Continuous improvement of products is a policy of Zebra Technologies. All specifications and designs are subject to change without notice.

- Liability Disclaimer

Zebra Technologies takes steps to ensure that its published Engineering specifications and manuals are correct; however, errors do occur. Zebra Technologies reserves the right to correct any such errors and disclaims liability resulting therefrom.

- Limitation of Liability

In no event shall Zebra Technologies or anyone else involved in the creation, production, or delivery of the accompanying product (including hardware and software) be liable for any damages whatsoever (including, without limitation, consequential damages including loss of business profits, business interruption, or loss of business information) arising out of the use of, the results of use of, or inability to use such product, even if Zebra Technologies has been advised of the possibility of such damages. Some jurisdictions do not allow the exclusion or limitation of incidental or consequential damages, so the above limitation or exclusion may not apply to you.

Warranty

For the complete Zebra hardware product warranty statement, go to: www.zebra.com/warranty.

Service Information

Before you use the unit, it must be configured to operate in your facility’s network and run your applications.

If you have a problem using your equipment, contact your facility’s Technical or Systems Support. If there is a problem with the equipment, they will contact the Zebra Global Customer Support at www.zebra.com/support.

For the latest version of this guide go to: www.zebra.com/support.

Features

Figure 1 RS5100 Single Trigger Configuration Features

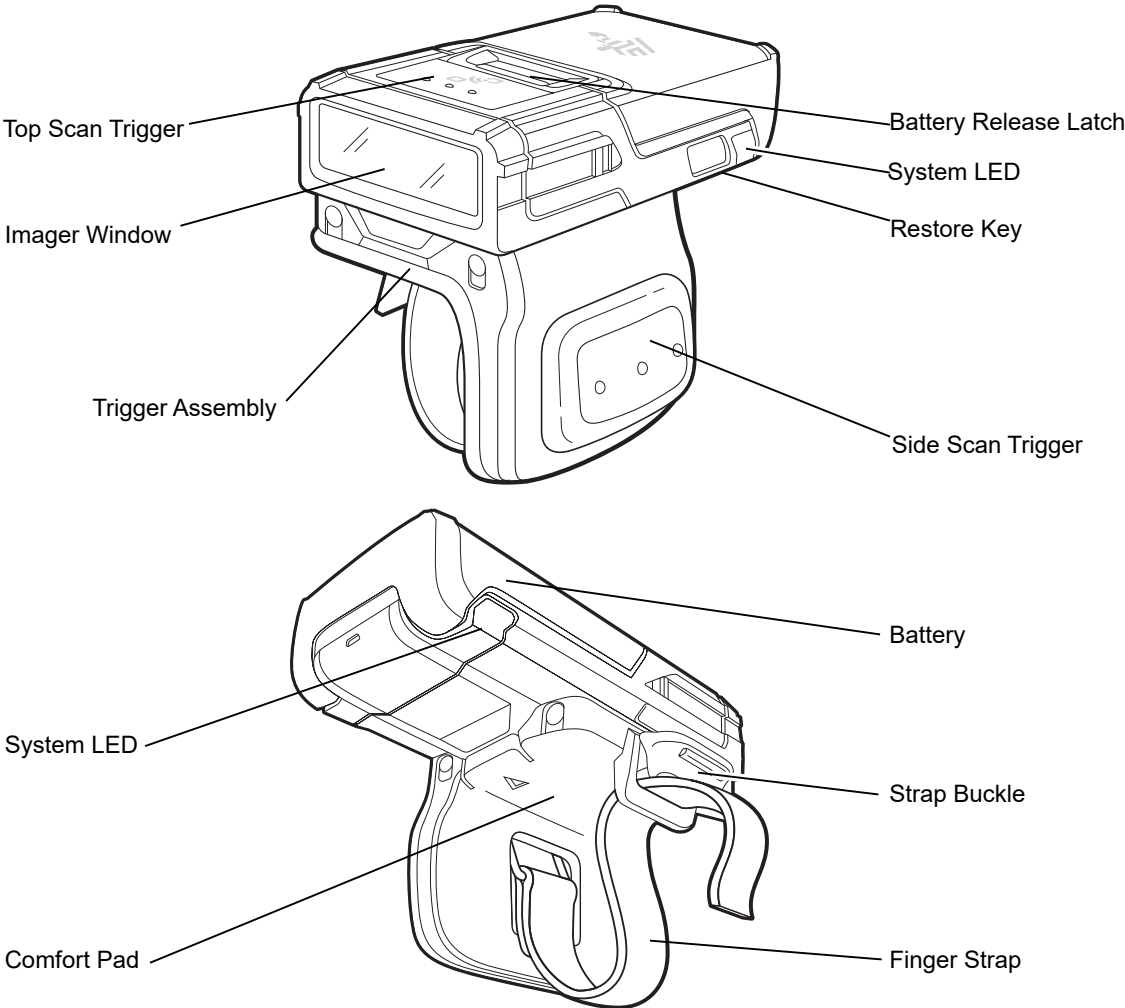

Installing the Battery

1. Align the battery on top of the RS5100 and insert into the battery compartment.

Figure 2 Install the Battery

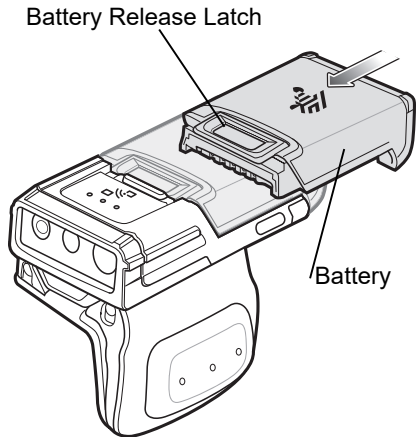

2. Slide the battery all the way into the locking slot of the RS5100.
3. Firmly press the battery into the RS5100 until a click is heard ensuring the battery release latch is fully engaged with the RS5100.

 **NOTE:** Brand new batteries from the factory are shipped in Ship Mode for protection, and need to be plugged into a charger (cradle or battery toaster) to activate the battery.

Removing the Battery

1. Push the battery release latch down until the latch pops up.

Figure 3 Release Battery

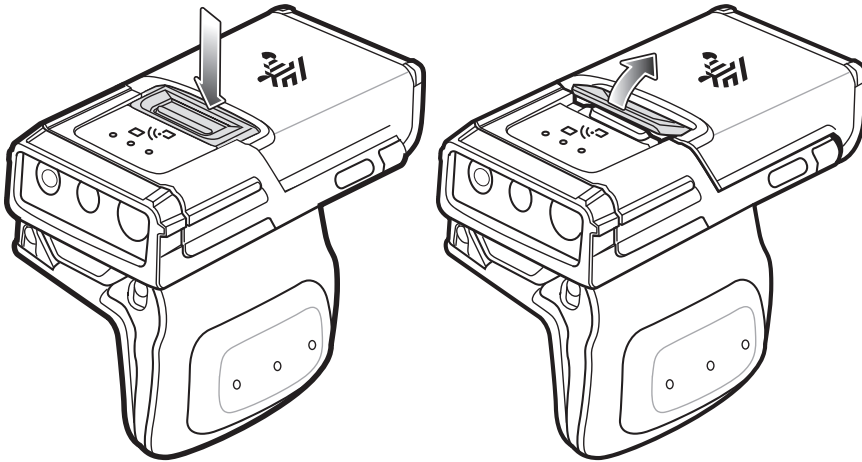

2. Slide the battery out of the battery compartment.

Figure 4 Remove the Battery

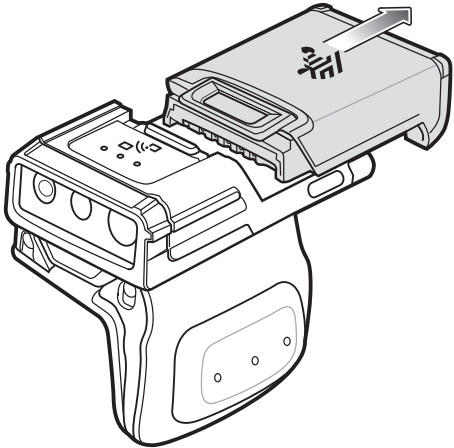

Mounting the RS5100

1. Slide the RS5100 onto the index finger with the Scan Trigger next to the thumb.

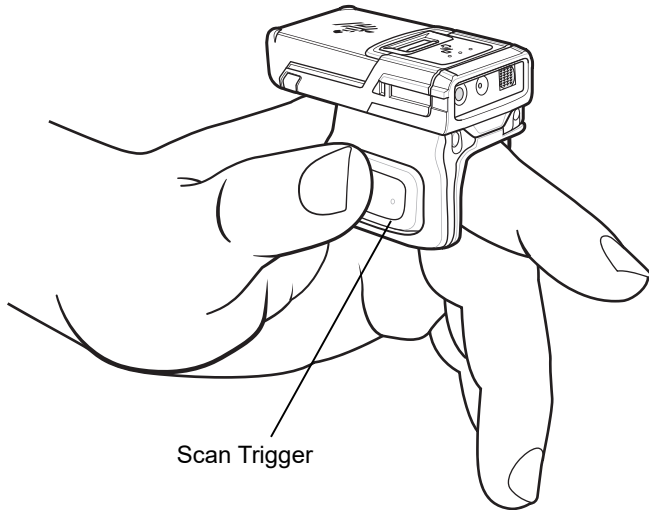

2. To tighten the Finger Strap, pull the end of the strap through the Strap Buckle. To loosen the Finger Strap, lift the Strap Buckle away from the Finger Strap while pulling the strap through the Strap Buckle. Release the Strap Buckle to hold the Finger Strap in place.

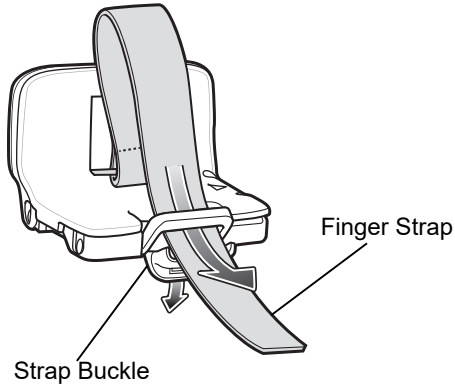

Powering On

To power on the device:

1. Install the battery (if not already installed).

 **NOTE:** Brand new batteries from the factory are shipped in Ship Mode for protection, and need to be plugged into a charger (cradle or battery toaster) to activate the battery.

2. Press the yellow side scan trigger.

Bluetooth Connection

 **NOTE:** The connection methods below apply only to Zebra Mobile Computers. For more information, refer to the RS5100 Product Reference Guide.

NFC Tap-to-Pair

The RS5100 is NFC enabled and supports Bluetooth Tap-to-Pair.

To connect with a device, such as the WT6000 or TC52:

1. Check that NFC is enabled on the device.
2. Align the NFC icon on the RS5100 with the NFC icon on the device.

The Status LED blinks blue indicating that the RS5100 is attempting to establish connection with the device. When a connection is established, the Status LED turns off and the RS5100 emits a single string of low/high beeps.

Figure 5 Touch NFC Antennas

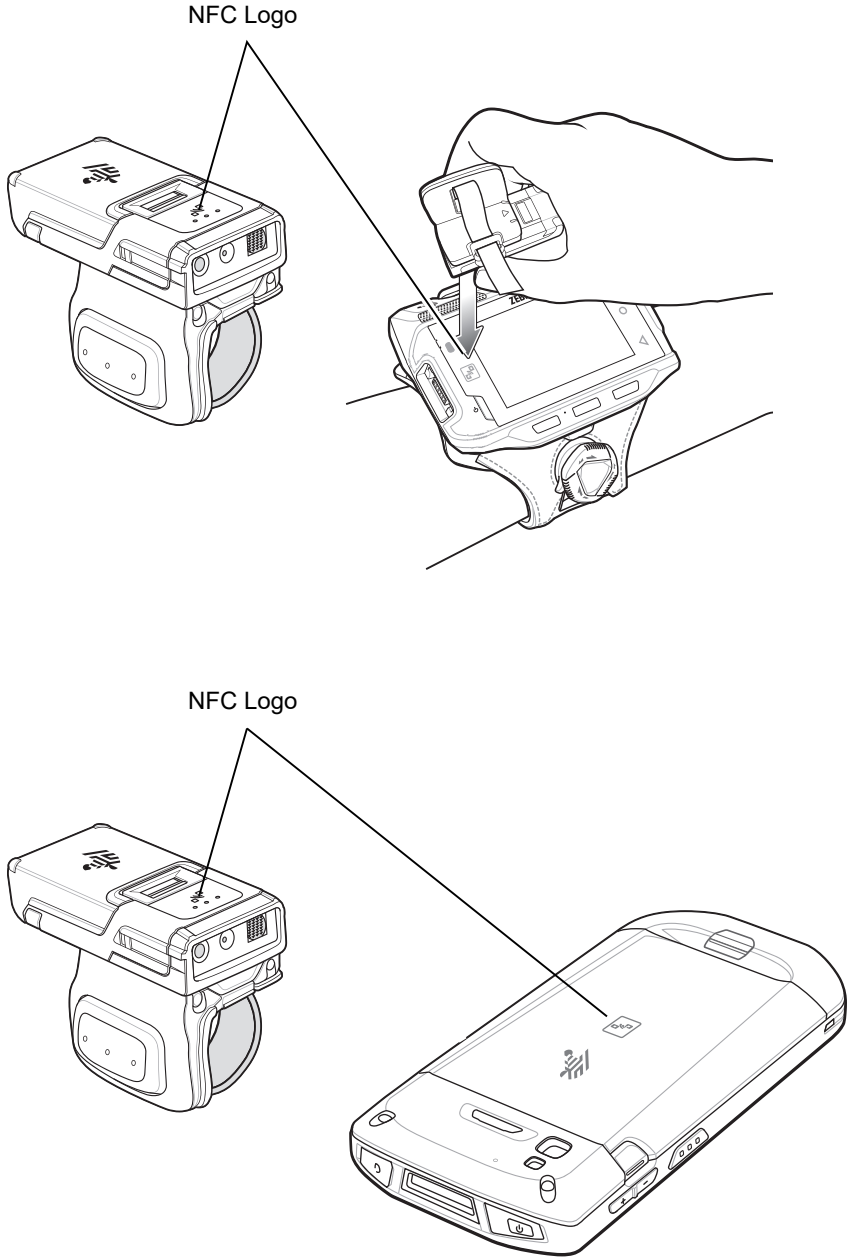

NOTE: Not all Zebra devices support NFC readers and the Tap-to-Pair feature.

Scan2Pair

To pair the RS5100 with a device, such as the WT6000 or TC52 using SSI:

1. On the device, touch  > . The Bluetooth Pairing Utility opens.

Figure 6 Bluetooth Pairing Utility



2. Using the RS5100, scan the barcode on the screen.

The Status LED blinks blue indicating that the RS5100 is attempting to establish a connection with the device. When a connection is established, the Status LED turns off and the RS5100 emits a single string of low/high beeps.

The device indicates a successful pairing attempt with a toast notification (audio and visual). When the Bluetooth connection is established, pop-up notifications appear on the device's screen.

3. On the device, touch  to return to the main screen.

Scanning

The RS5100 is available with two scan engine options: the SE4710 and SE4770. The SE4710 emits an orange LED dot aimer, while the SE4770 emits a red laser cross-hair aimer. For information on enabling scanning, refer to the RS5100 Product Reference Guide.

RS5100 Scanning with SE4710

To scan a barcode:

1. Launch a scanning application.
2. Press the Scan Trigger and aim the device at a barcode.
3. Adjust the position of the device so that the orange aiming dot appears at the center of the barcode.

Ensure the barcode is within the area formed by the aiming pattern. The aiming dot is used for increased visibility in bright lighting conditions.

The Status LED illuminates red. Upon successful decode, the Status LED changes from red to green and an audible beep sounds.



NOTE: When the device is in Picklist Mode, the imager does not decode the barcode until the crosshair or aiming dot touches the barcode.

4. Release the Scan Trigger.
The barcode data displays on the screen.

RS5100 Scanning with SE4770

To scan a barcode:

1. Launch a scanning application.

2. Press the Scan Trigger and aim the device at the barcode.
3. Adjust the position of the device so that the red laser cross-hair appears at the center of the barcode.
4. The status LED illuminates red. Upon successful decode, the status LED changes from red to green and an audible beep sounds.

 **NOTE:** In some configurations proper decoding of a barcode is indicated by the software application running on the mobile computer.

Charging

 **NOTE:** Ensure that you follow the guidelines for battery safety described in the RS5100 Product Reference Guide.

Use one of the accessories in the following table to charge the RS5100 and/or spare battery.

Table 1 Charging and Communication

Description	Part Number	Charging		Communication	
		Battery (In Device)	Battery Only	microUSB to USB	Ethernet
4-Slot RS5100 Charge Only Cradle	CRD-RS51-4SCHG-01	Yes	No	No	No
20-Slot RS5100 Charge Only Cradle	CRD-RS51-20SCHG-01	Yes	No	No	No
8-Slot Battery Charger	SAC-RS51-8SCHG-01	No	Yes	No	No
40-Slot Battery Charger	SAC-RS51-40SCHG-01	No	Yes	No	No

Refer to the RS5100 Product Reference Guide, for detailed information on all charging accessories.

Charging the RS5100

To Charge the RS5100:

1. Insert the RS5100 into the RS5100 charging slot with the scan window facing the charge contacts.

Figure 7 Insert RS5100 into Cradle

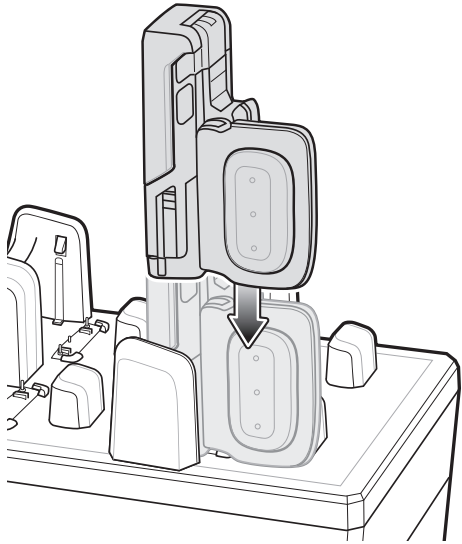

2. Ensure that the RS5100 is properly seated in the charging slot.



NOTE: It is suggested to charge the RS5100 before doing a firmware update over Bluetooth.

Charging the Spare Battery

1. Insert a spare battery into the spare battery slot.

Figure 8 Insert Battery into Cradle

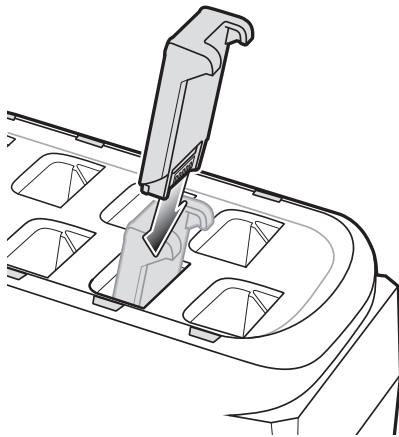

2. Ensure the battery is seated properly. The Spare Battery Charging LED blinks indicating charging.

Battery Charging

The RS5100 Charging LED indicates the charging status of the battery in the RS5100 and the Spare Battery Charging LED indicates the charging status of the spare battery. See [Table 2 on page 10](#).



NOTE: Brand new batteries from the factory are shipped in Ship Mode for protection, and need to be plugged into a charger

(cradle or battery toaster) to activate the battery.

Table 2 Charging LED Indicators

State	Indication
Off	The battery is not charging. The RS5100 or battery is not inserted correctly in the cradle or connected to a power source. Cradle is not powered.
Solid Amber	Battery is charging.
Solid Green	Battery charging is complete.
Fast Blinking Red (2 blinks/second)	Charging error, e.g.: - Battery temperature is too low or too high for charging. - The battery has reached the charge cycle time-out period. Battery charging has gone on too long without completing a full charge cycle (typically eight hours).
Solid Red	Unhealthy battery is charging or fully charged.

Charge batteries in temperatures from 5°C to 40°C (41°F to 105°F). The standard battery charges from 0% to 90% in less than two and a half hours at room temperature. When the charging temperature is from 5°C to 10°C (41°F to 50°F), the standard battery charges in less than five hours.

The device and cradle monitor the battery temperature. Battery charging is only performed when the battery is within safe charging temperature limits. At higher temperatures (e.g. approximately +35 °C (+95 °F)) the device or charging cradle may for small periods of time alternately enable and disable battery charging to keep the battery at acceptable temperatures. This process may require additional time to complete a full charge cycle. The RS5100 or cradle indicate when charging is disabled due to abnormal temperatures via the Status LED.

4-Slot RS5100 Charge Only Cradle

Figure 9 4-Slot RS5100 Charge Only Cradle

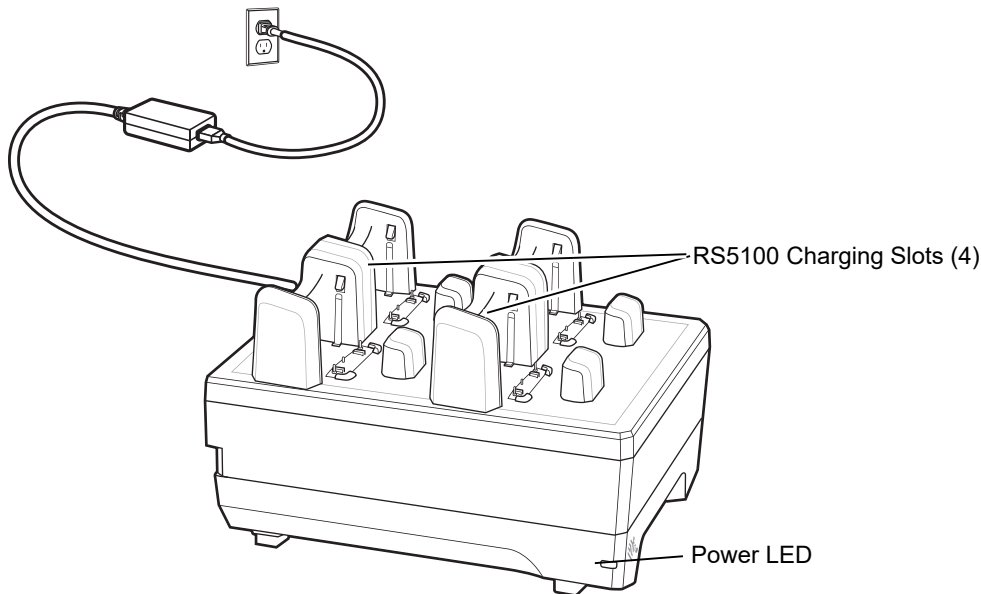

8-Slot Battery Charger

Figure 10 8-Slot Battery Charger

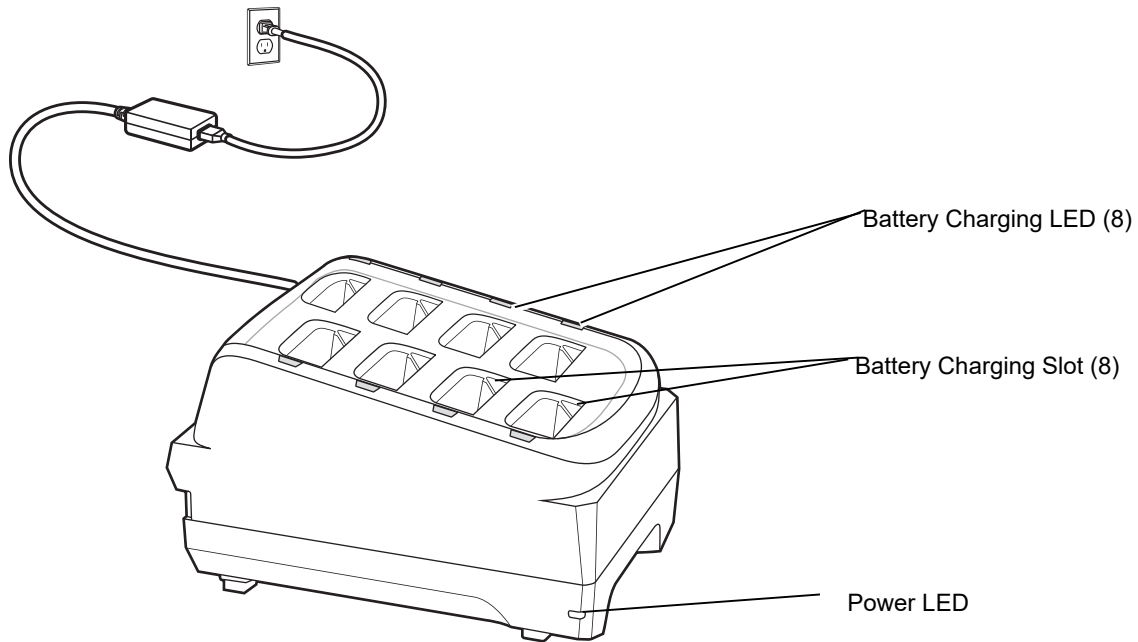

Ergonomic Considerations

- Reduce or eliminate repetitive motion
- Maintain a natural position
- Reduce or eliminate excessive force
- Keep objects that are used frequently within easy reach
- Perform tasks at correct heights
- Reduce or eliminate vibration
- Reduce or eliminate direct pressure
- Provide adequate clearance
- Provide a suitable working environment
- Improve work procedures.

